



# Bolted Repair Design and Process Considerations

Jeff Berner

787 Wing/Empennage/  
Landing Gear

Presented to CACRC, May 9-11, 2007

Building the Dream

787 DREAMLINER™

# Agenda

787 DREAMLINER™

- **Introduction**
- **Design for Repairability**
- **Bolted Repair Design Considerations**
- **Bolted Repair Analytical Considerations**
- **Material/Fastener Selection**
- **Bolted Repair Process Sensitivity**
- **Conclusions**

# Introduction

787 DREAMLINER™

Aircraft structure is exposed to a variety of damage threats in-service....  
...from Mother Nature....

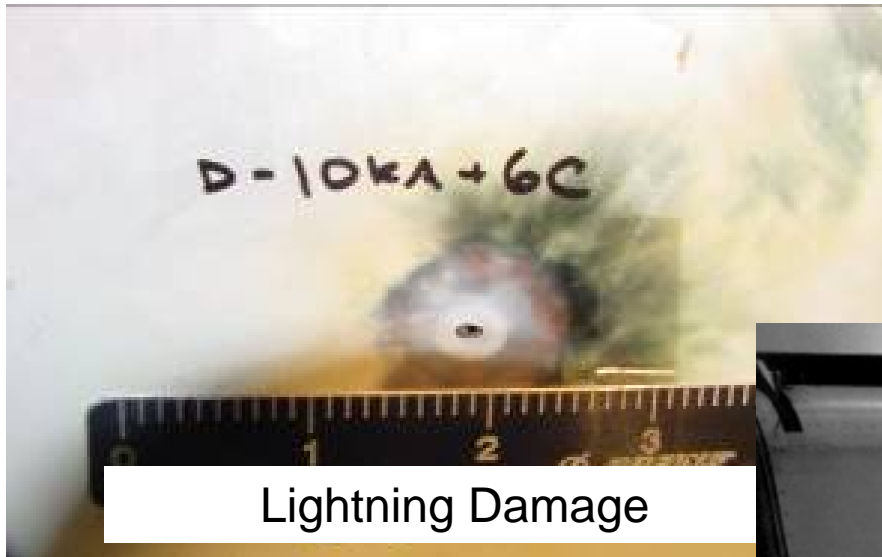

Lightning Damage



Ground Hail

# Introduction

Aircraft structure is exposed to a variety of damage threats in-service....

...from Mother Nature....

...from airport operations...



Ground Handling Equipment

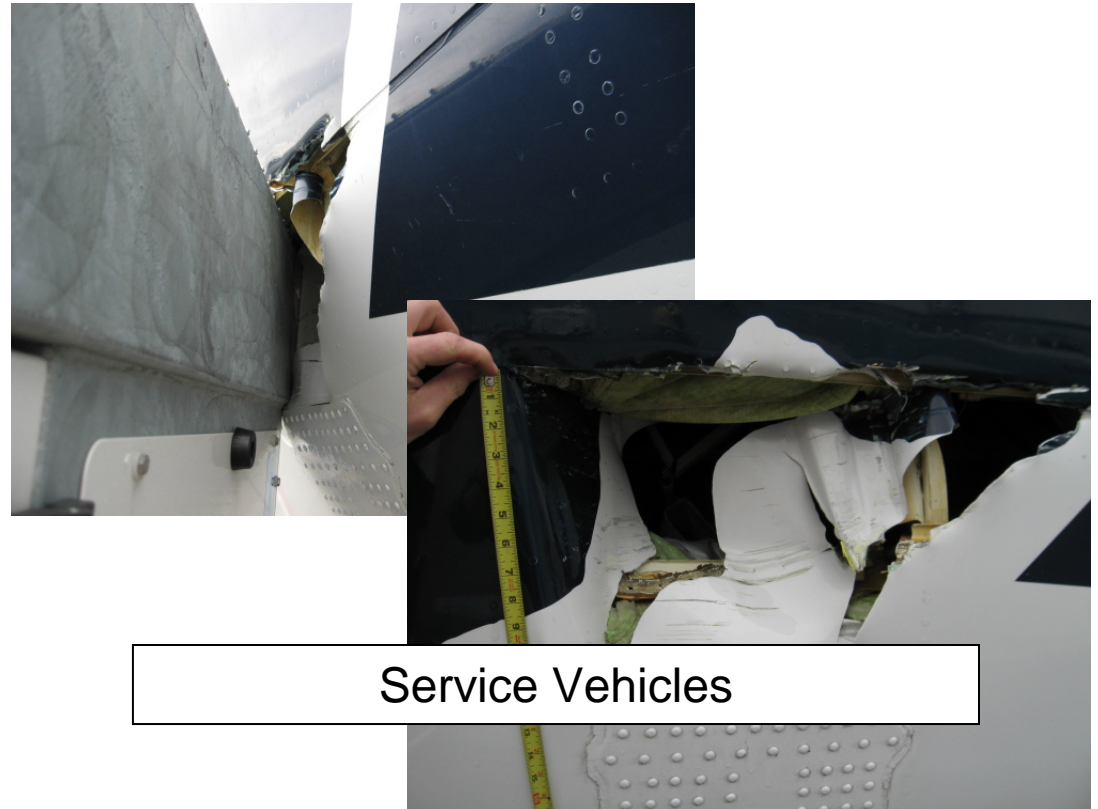

Service Vehicles



# Introduction

787 DREAMLINER™

Aircraft structure is exposed to a variety of damage threats in-service....

...from Mother Nature....

...from airport operations...

...from maintenance...



Maintenance Stand

# Introduction

787 DREAMLINER™

Aircraft structure is exposed to a variety of damage threats in-service....

...from Mother Nature....

...from airport operations...

...from maintenance...

...and from pilots.

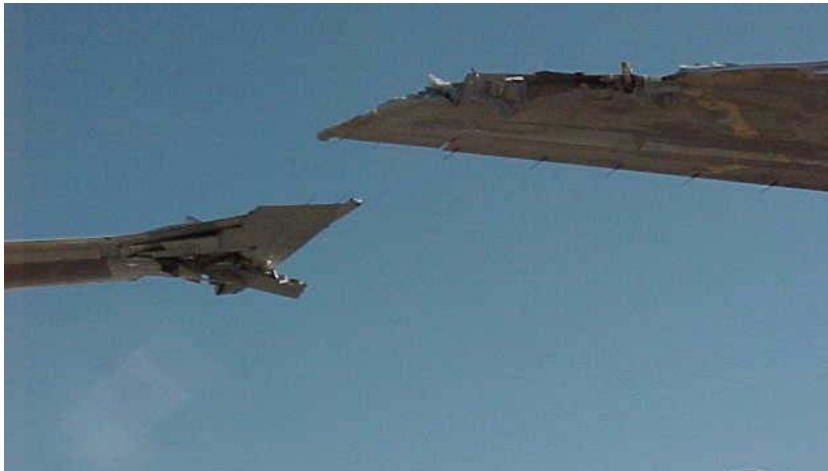

Collision



Tail Strike

# Introduction

787 DREAMLINER™

Aircraft structure is exposed to a variety of damage threats in-service....

...from Mother Nature....

...from airport operations...

...from maintenance...

...and from pilots.

Meeting airline expectations for repairability begins with an understanding of the threat environment and the repairs that may be expected in-service.

Airlines require a variety of repair options which permit them to choose the best repair for the situation.

When a large damage occurs, bonded repairs may become impractical or technically not feasible and a bolted repair design will be required.

Fail-safety principles may direct use of bolted repairs when a bonded repair size may exceed the residual strength of the component should the bondline fail.

**Implementation of successful repair begins in the initial design phase.**

**On the 787, Boeing initiated a more disciplined process during initial design to ensure that airframe structural components could be repaired using a range of bonded repair materials and bolted repair.**

**Design considerations –**

- **Notch sensitive layups avoided** 
- **Chord and cap widths have area and edge margin to permit fastened repairs**
- **Added gauge or edge margins in areas prone to damage**
- **Add protective features to prevent damage from occurring**
- **Balance weight/robustness based upon proven service experience (e.g. min gage for sandwich structure)**



## Common bolted repairs designed for SRM incorporation

- 1 Identify Common Structure

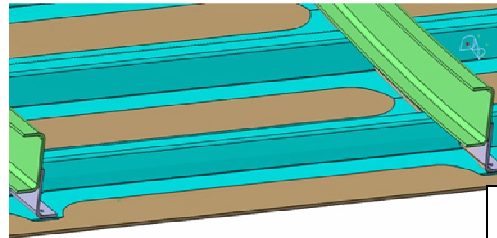

Skin/Stringer

- 2 Evaluate risk of accidental damage
- 3 Develop standard repairs for scenarios judged to be frequent

Formed metallic doubler

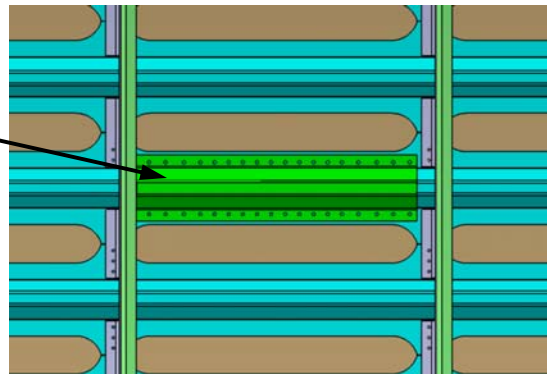

- 4 Large damages or rarely damaged components will be addressed upon occurrence

## Anticipated AOG Repair Events Considered

Example: Damage Scenario - Aft Body GSE Impact

External doubler repair developed-Time-Limited & Permanent repair options.

- Estimated flow & resources

### Time Limited Repair

2 Calendar days  
3 Mechanics  
~132 Manhours

### Permanent Repair

3 Calendar days  
3 Mechanics  
~198 Manhours

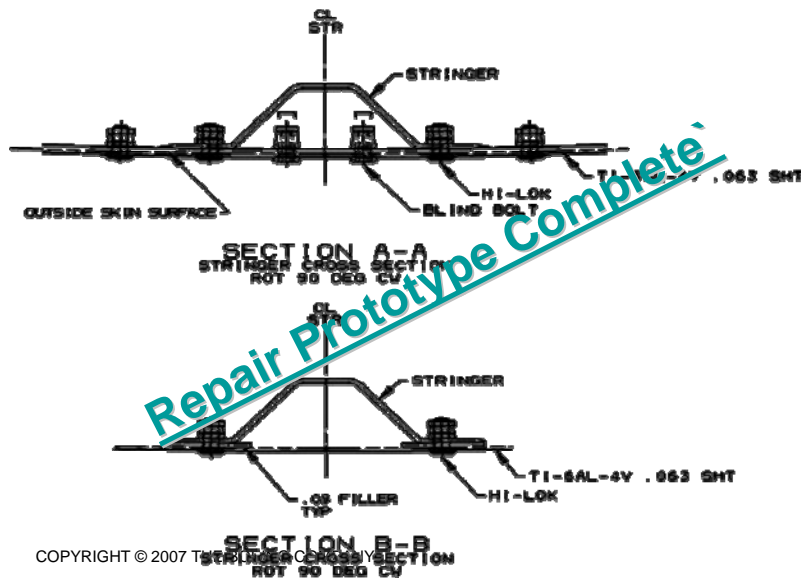

# Bolted Repair Design Considerations

787 DREAMLINER™

**When developing the design for a bolted repair, the repair engineer needs to account for –**

**Replacing load paths**

**Matching EA, EI**

- **hardpoint effects (load increase factor)**
- **repair effectiveness to reduce stress concentration due to damage**

**Determining the repair materials which may be available, e.g. titanium sheet, aluminum sheet**

**What fasteners might be available (type, diameter, grip length)**

**Producibility considerations, e.g. bend radius for formed sheet stock, accessibility for drill motors, one-sided access, etc.**

**Capability of mechanics conducting the repairs**

# Bolted Repair Analysis Considerations

787 DREAMLINER™

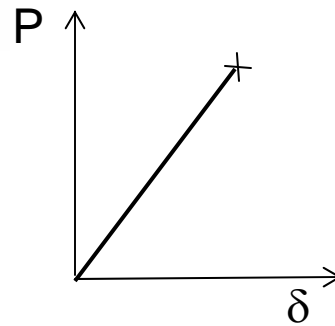
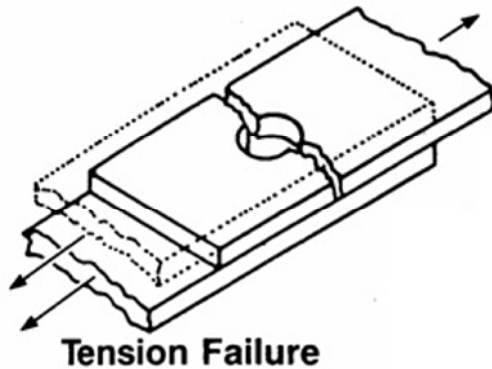

- Linear strain to failure and net-tension failure modes of CFRP composite require load share analysis for bolted joints.
- 2-D analysis is appropriate for components loaded along a single axis, e.g. stringers

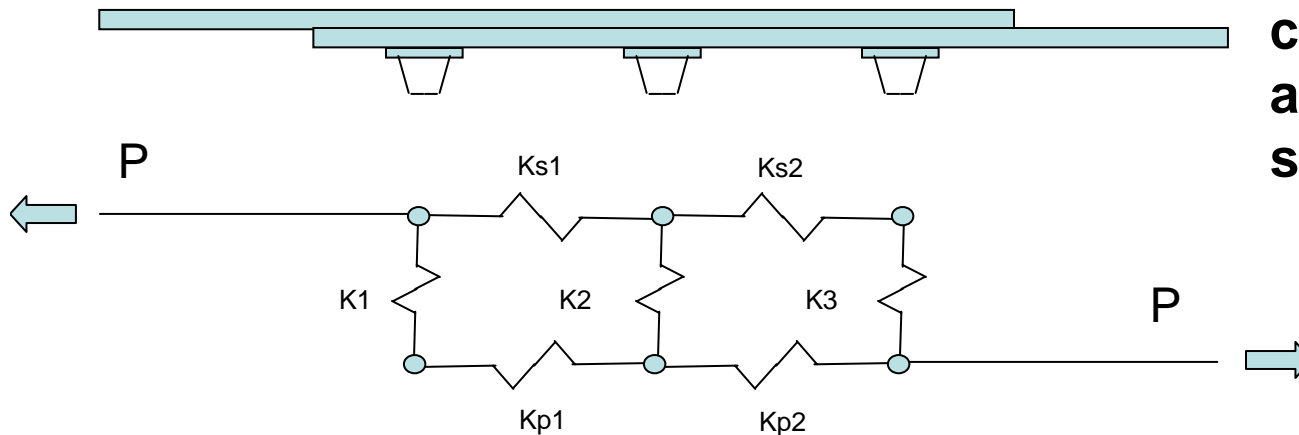

# Bolted Repair Analysis Considerations

787 DREAMLINER™

- **3-D analysis is appropriate for components with complex geometry or loaded with varied internal loads, e.g. door surround**

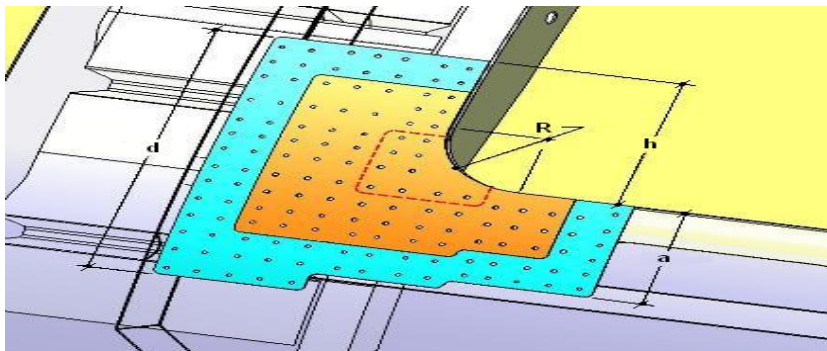

Objective:

- Build FEM of the door surround bolted corner repair to validate analysis methodology by correlating FEM output with calculated values.

FEM output requested.

- FEM Load Application
- Doubler Stress
- Highest fastener load (ULT)
- Percentage of load transfer - compare with hand analysis/2-D assessments.
- $K_t$  in corner (doubler)



# Bolted Repair Analysis Considerations

787 DREAMLINER™

## Door Surround Detailed Finite Element Model

Detailed FEM

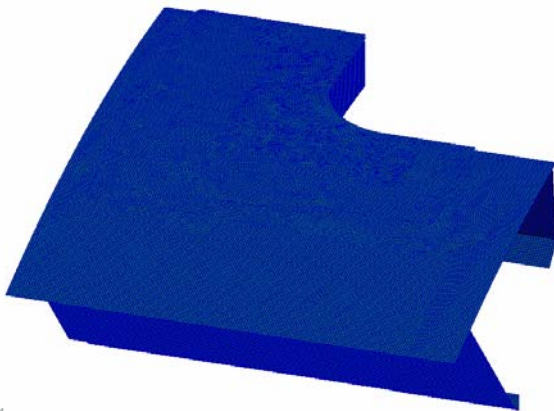

Maximum Stresses

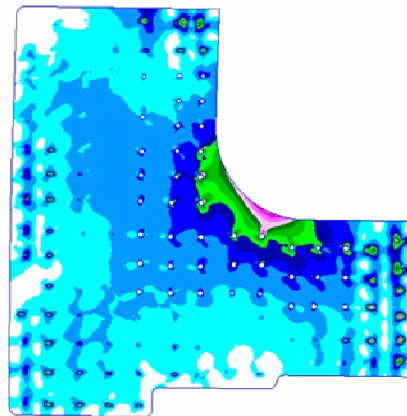

Calculate doubler peak stresses  
Fatigue assessment

Peak Fastener Loads

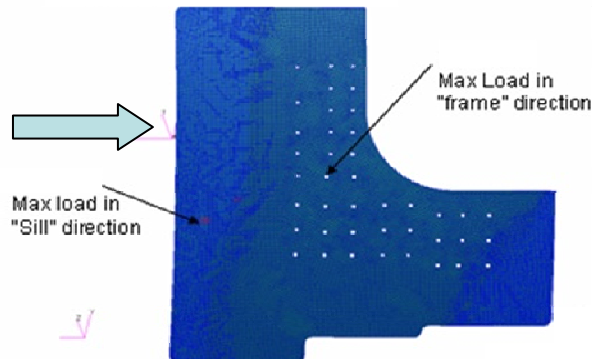

Fastener shear  
Fastener bending  
Composite bearing/bypass interaction  
Doubler bearing stress

NOTE: FEM methods requires validation through comparison to hand-analysis or to test results.

# Bolted Repair Analysis Considerations

787 DREAMLINER™

## Concerns for Composite Bolted Repair

Since CFRP is linear-elastic, repair materials should exhibit linear stress-strain relationship. Good: Ti 6Al-4V Poor: Al 2024, CRES 301

Differences in material coefficients of thermal expansion (CTE) need to be taken into account in the analysis. CTE mismatch adds fastener load to critical fasteners. FE methods are appropriate.

Eccentricities may be larger in composite-metal repairs due to thicker gages of composites as compared to metal repair materials.

Fastener failure modes need to be avoided-

- high t/d ratios
- weak fastener heads (e.g. 130-deg, 100-deg reduced shear)
- thick shims → eccentricity
- loss of clamp-up
- clearance fit holes
- high-load reversals / vibratory environment which may cause hole wear and fastener rotation
- fay-surface sealant
- shim type (e.g. peelable shims)

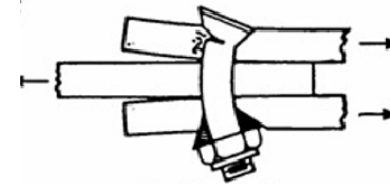

**Bolt Failure**



**1/4-Inch Diameter Titanium Hex-Drive Fasteners with CRES Tension Collars, Ti-CFRP-Ti Stacks, t/d = 2.1–2.7**

# Material/Fastener Selection

787 DREAMLINER

Materials, Finishes and Fasteners need to be consistent with structural requirements, EME requirements, and corrosion protection requirements

- Repairs need to be tested to validate that EME requirements are met. Fuel tanks and airplane systems may dictate different EME requirements than for metal airframe structure.
- Repair materials need to be either compatible for galvanic corrosion or finishes/sealants must prevent galvanic corrosion. Sealants may reduce fatigue life and adversely affect static joint strength.
- One-sided fasteners where used require back-side inspection. One-sided fasteners may require more frequent inspection due to concerns with loss of clamp-up.

# Bolted Repair Process Sensitivity

787 DREAMLINER™

There is a perception that a bonded repair is highly susceptible to process variability and thus a bolted repairs are preferable. Bolted repairs exhibit process sensitivity as well which needs to be accounted for:

- meeting close tolerance hole requirements
- using backup to avoid fiber breakout
- using dull bits or incorrect speeds/feeds which can cause heat damage to metal or “burn” composite
- shimming & fit-up stresses
- application of sealant
- drilling through metal/composite stackup. Metal chips can cause damage to composite holes
- drill wandering or hole misalignment if drill guides are not used
- deburring holes

When they occur, such failures in process are likely to occur throughout the repair and not at individual locations within the repair.

# Conclusions

787 DREAMLINER™

- **Ability to accomplish bolted repairs needs to be considered during initial design when choosing layup and structural configuration**
- **Bolted repairs may be planned for based upon service experience which indicates susceptibility to damage and the types of damage events**
- **Structural analysis for bolted repair will likely require as extensive analysis (if not more) than what is required for initial design. This is required because failure-modes are different for composite-metal bolted repairs than for repairs to metal aircraft**
- **As with any repair, materials, fasteners and finishes need to be selected to be compatible with the application and requirements.**
- **As with any repair, attention to detail and adherence to processes are required**



 **BOEING**



Building the Dream

787 DREAMLINER™